

MORSPACE

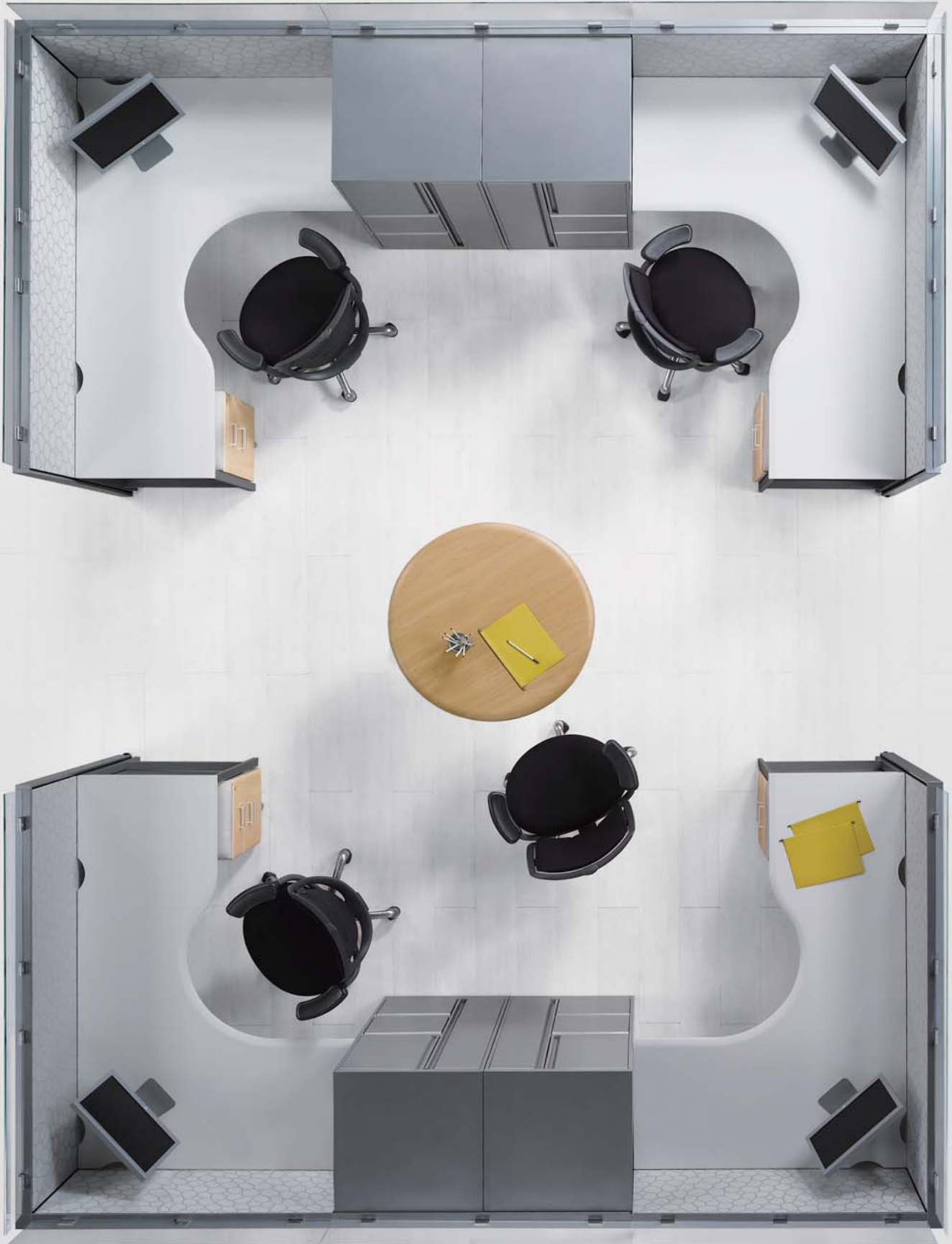

MORSPACE, the Affordable Green Solution

MAI presents MORSPACE the first affordably priced green office system. Framing is constructed from recycled steel, and acoustical tiles are produced with 100% post-consumer P.E.T. from ground-up soda bottles. Patented plug-and-play voice, data and power cabling can be reused instead of ending up in landfills. Fabrics for panels are available in recyclable Eco Intelligence® polyester, a new standard for sustainability. Large orders are shipped directly from the factory to job site circumventing the normal delivery channel and dramatically reducing our carbon footprint.

GREENGUARD® Certified

MAI products are certified by the GREENGUARD Environmental Institute. This indicates that an approved laboratory has tested our products, and they meet GREENGUARD's stringent emissions standards for indoor air quality.

MAI Products Contribute to LEED® Certification



LEED for Commercial Interiors is the green benchmark for the tenant improvement market. It is the recognized system for certifying high-performance green interiors that are healthy, productive places to work, less costly to operate and maintain, and have a reduced environmental footprint. LEED for Commercial Interiors gives the power to make sustainable choices to tenants and designers who do not always have control over the entire building operations.*

*LEED Green Building Rating System.



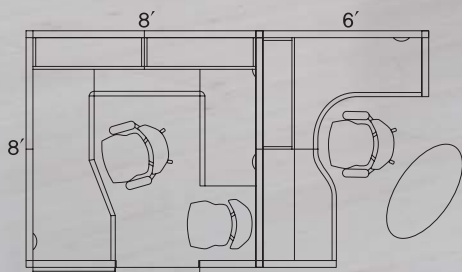

Paint: Warm White
 Panel Fabric: Design Tex Quasar 102 Sand
 Worksurfaces and Ped Fronts: Coverseal Walnut
 Table Top: Coverseal Warm White
 Glass: Clear
 Seating Upholstery: Leather 102 Ivory



Team Meeting
09:30

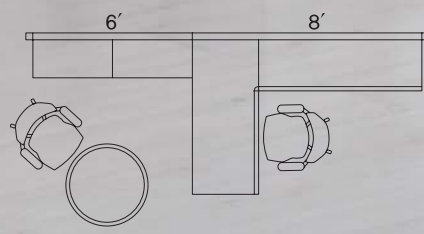

Paint: Warm White
 Panel Fabric: Maharam Giga Point 002 Ecrú
 Worksurfaces: Coverseal Warm White
 Table Top and Peds Fronts: Coverseal Walnut
 Seating Upholstery: Leather 102 Ivory

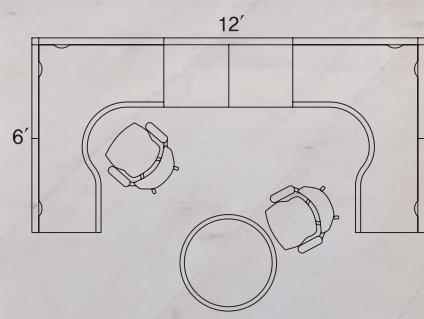

Paint: Titanium Metallic
 Panel Fabric: Luna Stepping Stones 93 Egg
 Worksurfaces: Coverseal Frosty White
 Table Top and Ped Fronts: Coverseal Maple
 Top Glass: Clear
 Seating Upholstery: Midtown 46 Black Out

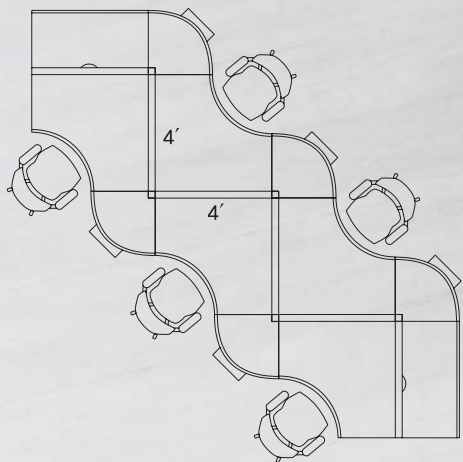

Paint: Dusk
Panel Fabric: SELECT Immersion 509 Tuscany
Worksurfaces and Ped Fronts: Coverseal Warm White
Top Glass: Frosted
Cushion Top: Design Tex 701 Soda Pop
Seating Upholstery: Midtown 41 Pavement

Quality Features



Up Mounted Bin



Storage Tower



Squared Panel Trim



Tool Bar with Accessories



Mobile Table Base



Frame End Support



Full Depth Pedestal



Top Mounted Glass



Mobile Pedestal with Cushion Top



Coverseal Worksurface



Frameless Glass Tile



Table Pedestal Base

Tile Options



Clear Glass



Frosted Glass

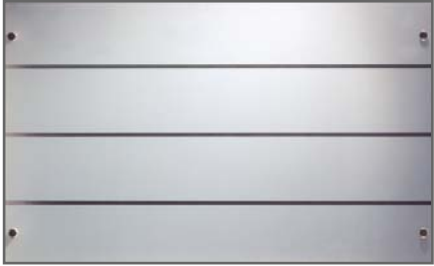

Banded Glass

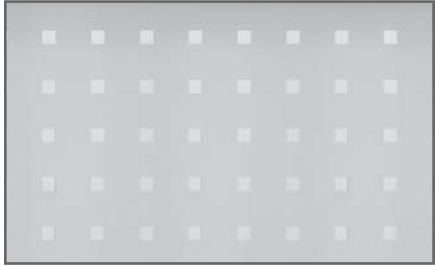

Square Glass



Tackable/Acoustical



Fabric Covered

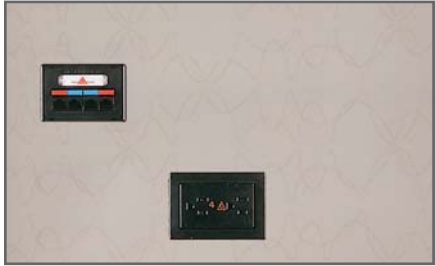

Power and Data



Marker Board

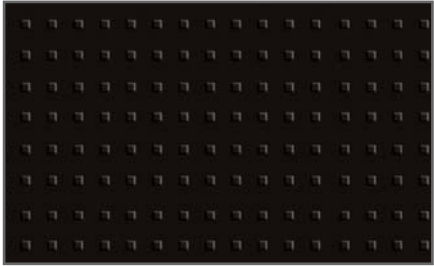

Embossed Steel



Painted Steel

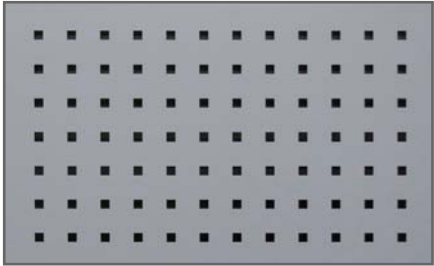

Square Airflow



Round Airflow

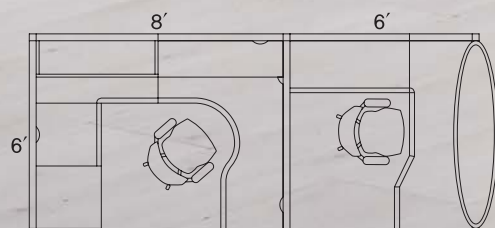

Paint: Mica Metallic
Panel Fabric: Design Tex Ringlet 103 Aluminum (outside);
Design Tex Cut-to-the-Chase 101 Egg Shell (inside)
Worksurfaces and Ped Fronts: Coverseal Warm White
Top Glass: Frosted
Seating Upholstery: Climate 27F Cirrus

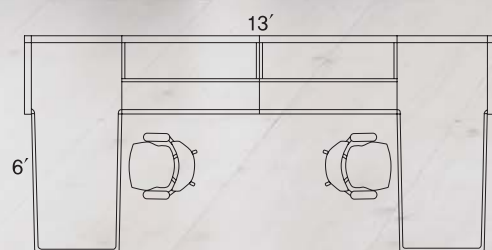

Paint: White
 Panel Fabric: Luna Mezzanine 3001 Bone
 Worksurfaces: Coverseal Frosty White
 Ped Fronts: Anigre
 Seating Upholstery: Leather 101 Black

Frame Technology

MORSPACE is technology friendly. Four-circuit, eight-wire power is available at the baseline or beltline. Incorporated into every panel frame are standards-based cable management pathways that accommodate up to 250 Category 6 cables. Zone distribution and plug-and-play connectors provide unmatched flexibility in accommodating moves, adds and changes.



Wiring

MORSPACE incorporates state of the industry technology features.



1 Baseline to Beltline Power



2 Beltline to Beltline Power

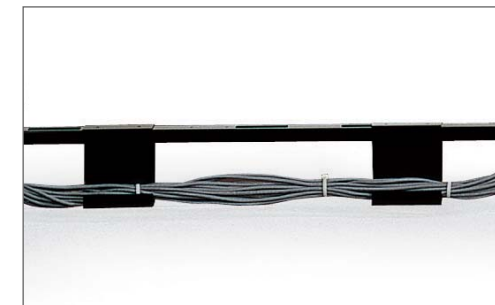

3 Cable Management Trough

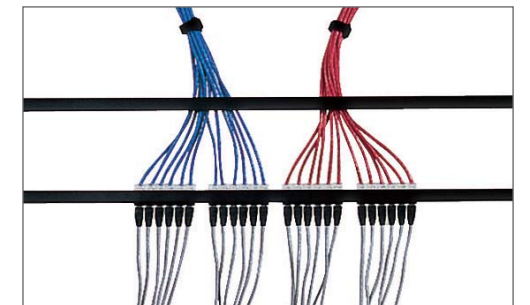

4 Interconnection Bracket

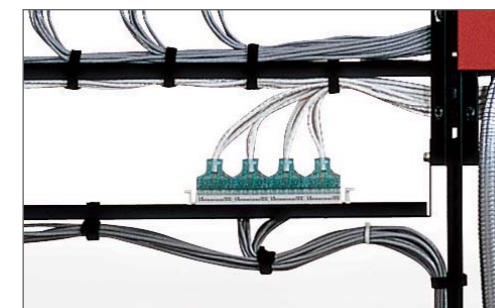

5 Plug-and-Play Connectors

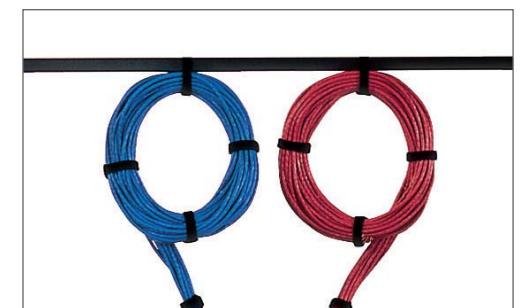

6 Slack Cable Loops



Modular Architectural Interiors

330 Waterloo Valley Road, Mount Olive, NJ 07828
p 973 446 2300 | f 973 446 2399
www.maispace.com